

# Schematic „family tree“ for Ni-Cr-Si-B-alloys (Niborite)/self-fluxing alloys

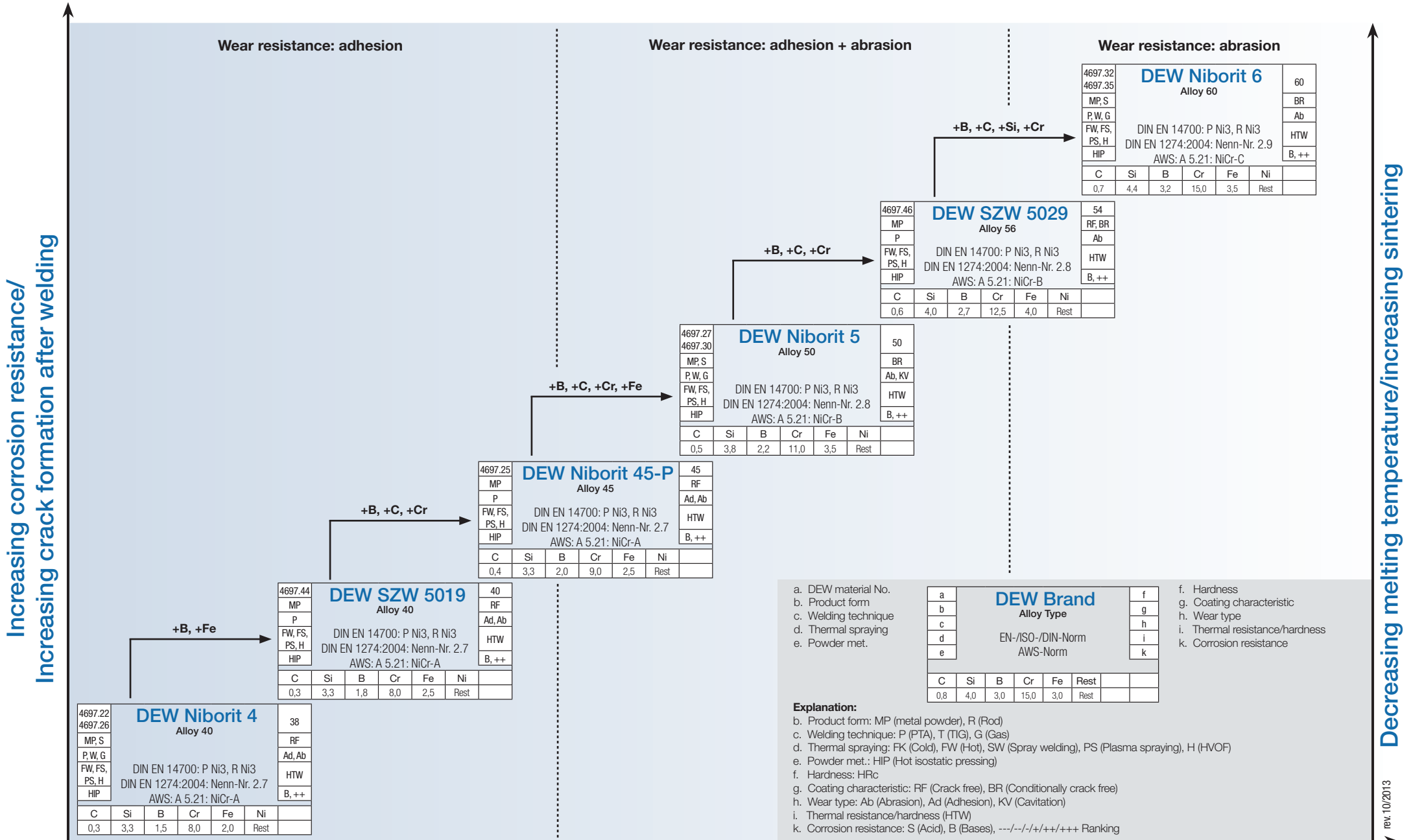

Member of Swiss Steel Group



Increasing corrosion resistance/  
Increasing crack formation after welding

Decreasing melting temperature/increasing sintering

Hardness

# Schematic „family tree“ for self-fluxing Ni alloys for the glass industry



Member of Swiss Steel Group

Powder Processing, PTA welding and thermal spraying

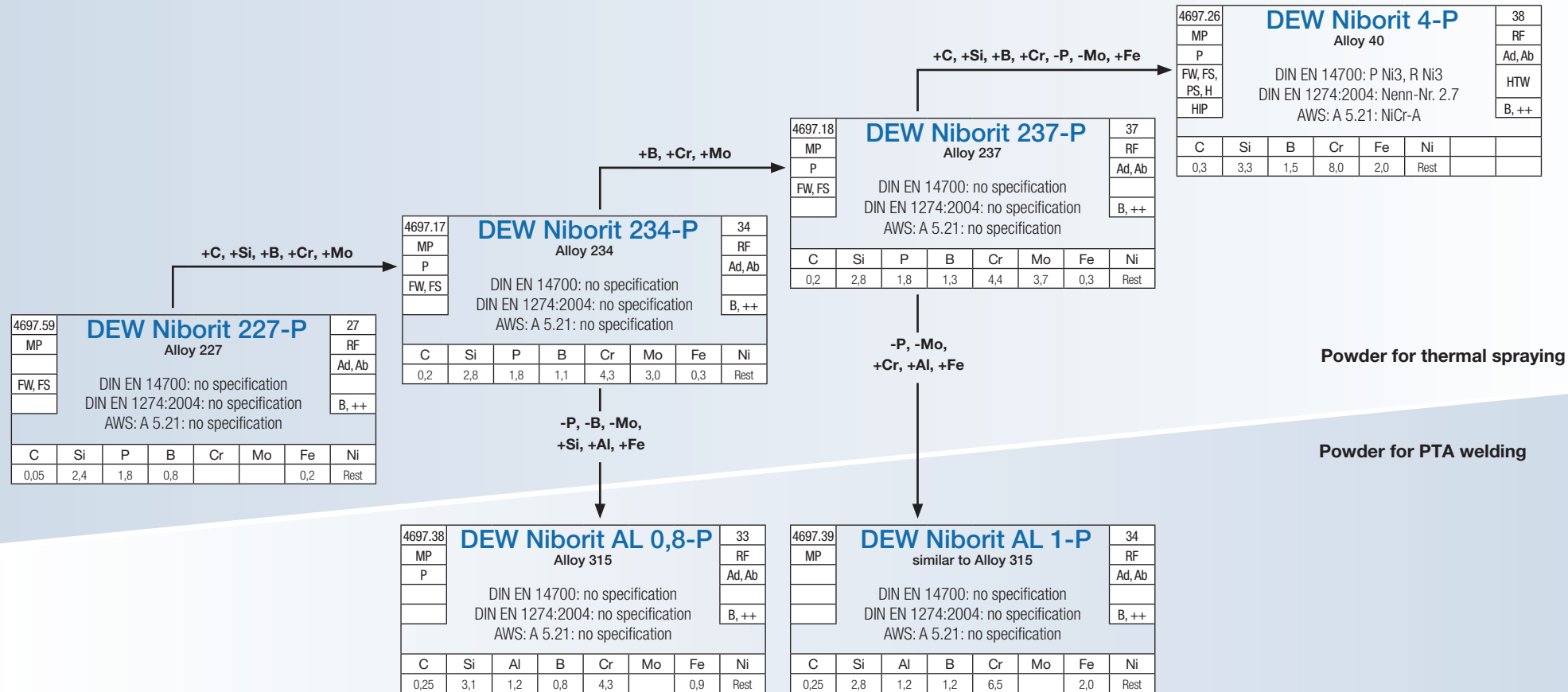

Powder for thermal spraying

Powder for PTA welding

- a. DEW material No.
- b. Product form
- c. Welding technique
- d. Thermal spraying
- e. Powder met.

a	DEW Brand Alloy Type						f
b	EN-/ISO-/DIN-Norm AWS-Norm						g
c							h
d							i
e							k
C	Si	B	Cr	Fe	Rest		
0,8	4,0	3,0	15,0	3,0	Rest		

- f. Hardness
- g. Coating characteristic
- h. Wear type
- i. Thermal resistance/hardness
- k. Corrosion resistance

**Explanation:**

- b. Product form: MP (metal powder), R (Rod)
- c. Welding technique: P (PTA), T (TIG), G (Gas)
- d. Thermal spraying: FK (Cold), FW (Hot), SW (Spray welding), PS (Plasma spraying), H (HVOF)
- e. Powder met.: HIP (Hot isostatic pressing)
- f. Hardness: HRc
- g. Coating characteristic: RF (Crack free), BR (Conditionally crack free)
- h. Wear type: Ab (Abrasion), Ad (Adhesion), KV (Cavitation)
- i. Thermal resistance/hardness (HTW)
- k. Corrosion resistance: S (Acid), B (Bases), ---/--/--/+/++/+++ Ranking

Increasing hardness with increasing B-content

no responsibility is taken for the correctness of this information

rev. 10/2013

# Schematic „family tree“ for self-fluxing Ni alloys for special applications



Member of Swiss Steel Group

Powder Processing, PTA welding or Brazing

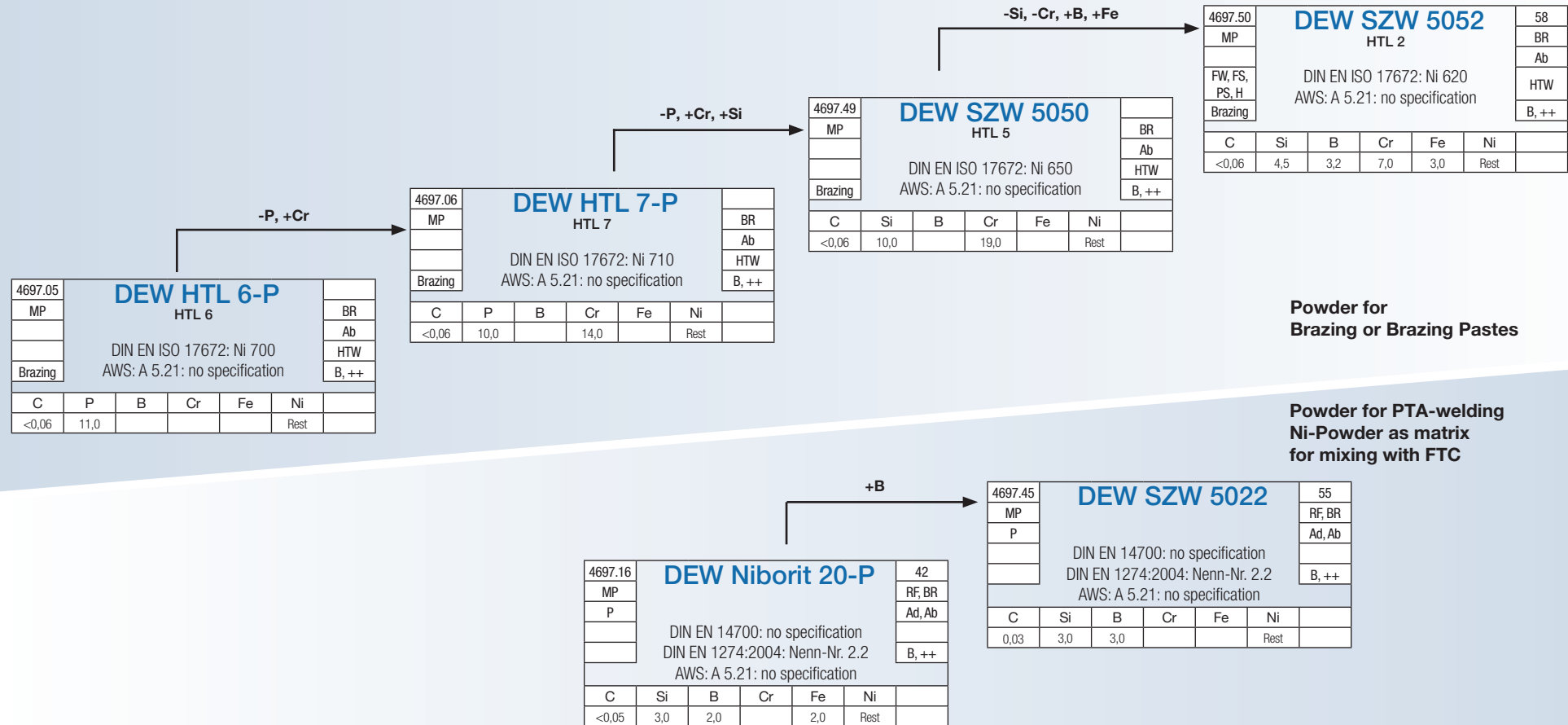

**Powder for  
Brazing or Brazing Pastes**

**Powder for PTA-welding  
Ni-Powder as matrix  
for mixing with FTC**

- a. DEW material No.
- b. Product form
- c. Welding technique
- d. Thermal spraying
- e. Powder met.

a	DEW Brand	f
b	Alloy Type	g
c		h
d	EN-/ISO-/DIN-Norm	i
e	AWS-Norm	k

C	Si	B	Cr	Fe	Rest
0,8	4,0	3,0	15,0	3,0	Rest

- f. Hardness
- g. Coating characteristic
- h. Wear type
- i. Thermal resistance/hardness
- k. Corrosion resistance

**Explanation:**

- b. Product form: MP (metal powder), R (Rod)
- c. Welding technique: P (PTA), T (TIG), G (Gas)
- d. Thermal spraying: FK (Cold), FW (Hot), SW (Spray welding), PS (Plasma spraying), H (HVOF)
- e. Powder met.: HIP (Hot isostatic pressing)
- f. Hardness: HRC
- g. Coating characteristic: RF (Crack free), BR (Conditionally crack free)
- h. Wear type: Ab (Abrasion), Ad (Adhesion), KV (Cavitation)
- i. Thermal resistance/hardness (HTW)
- k. Corrosion resistance: S (Acid), B (Bases), ---/--/+/++/+++ Ranking